



What is the Michigan Stained Glass Census?

The Michigan Stained Glass Census, which began in 1992, is a statewide survey of architectural stained glass that is sponsored by the Michigan State University Museum. With the help of Volunteer Census Takers, the Census is locating, recording and photographing stained glass windows throughout Michigan. The information collected by Census Takers is maintained in a computerized archive at the Michigan State University Museum. It will also be entered into the national Census of Stained Glass Windows in America, which has been underway since 1979.

The Michigan Stained Glass Census is an ongoing project that focuses attention on a long-neglected portion of Michigan's cultural heritage. By researching and recording information about the origins, styles, and subject matter of architectural stained glass, the Census is creating an invaluable resource of visual and documentary material related to Michigan's social, religious, and art history. The Census is also encouraging individuals and groups to better appreciate and preserve the stained glass treasures in their own communities.

How You Can Help with the Michigan Stained Glass Census

We appreciate your interest in helping with the Michigan Stained Glass Census. If you can tell us the locations of stained glass windows in your community or elsewhere in Michigan, please fill out the back of this form. The building might be a church, synagogue, public building, business place, or private home. The contact person might be a pastor, rabbi, business owner, administrator, or homeowner. After you have returned the form to us, we can then contact those persons for more information about the windows.

If you would like to be a Volunteer Census Taker and provide information about some stained glass windows in your community, please sign your name in the space provided on the back of this form. We will be glad to send you a set of Michigan Stained Glass Census forms and instructions on how to conduct your research. We hope you will participate in this important survey by documenting some of Michigan's stained glass treasures.

For more information, write to the address below:

**Michigan Stained Glass Census
Michigan State University Museum
East Lansing, MI 48824-1045**

Phone: 517-432-3800 or 517-627-8973

E-mail: stainedglass@museum.msu.edu

Web: <http://museum.msu.edu/museum/msgc/index.htm>

MICHIGAN STATE UNIVERSITY
MUSEUM

Michigan Stained Glass Census

Preliminary Survey Form

(Please type or print in black ink.)

Date: _____

Your Name: _____

Organization you represent (if applicable): _____

Your Address: _____
street

city county state zip code

Phone: _____ or _____ Fax: _____

E-mail: _____

Location of stained glass windows in your area (or elsewhere in Michigan):

Name of Building: _____

Building Address: _____
street city state zip code

Phone: _____ Contact Person: _____

Name of Building: _____

Building Address: _____
street city state zip code

Phone: _____ Contact Person: _____

Return this completed form to:

Michigan Stained Glass Census

Michigan State University Museum

East Lansing, MI 48824-1045

Phone: 517-432-3800 or 517-627-8973

Thank you for helping to discover, document and preserve Michigan's stained glass heritage!





We welcome your participation in the Michigan Stained Glass Census as a Volunteer Census Taker. The completion of the Michigan Stained Glass Census Forms A and B will involve careful examination of stained glass windows, the cooperation of contact persons at buildings where the windows are located, and reading of whatever records may be available. This research holds many rewards for the Census Taker. In addition to the pleasure of visiting local buildings and viewing their windows, there is the satisfaction of discovering and documenting long-forgotten information that can become part of the recorded history of the windows, the buildings, the local communities, and our state. By providing the information on these Census Forms to the Michigan Stained Glass Census, you are making an important contribution to our state's cultural history.

INSTRUCTIONS

The following suggestions will help you research stained glass windows:

LOCAL CONTACT: It helps to have a local contact at the building where you will be researching windows. The contact may be a minister, rabbi, church secretary, business owner or manager, building administrator, or homeowner. The contact person will help you schedule your visit and may suggest sources for the information you need.

PHOTOGRAPHY: If you can, work with a team of one or two other persons. One person can do the photography and the others can do the research and fill out the forms.

We prefer digital images. The image quality and organization of your images will directly influence the future usability of your materials for research and publication. The following hints will help when submitting digital images with your census forms:

1. Experiment with your camera in terms of lighting, focus, etc., with regards to stained glass windows. Practice shooting the windows multiple times before submitting your best images.
2. Set your camera to the highest resolution it will allow, and save the images in JPG or TIF format to a CD. Your filenames should match the numbering system of your building diagram, as well as any printouts you provide. Provide a CD and printouts of all of your images, preferably on photo paper. Digital printouts cannot be used for publication or web use. Any disk you provide will be stored separately from the paper materials in your file, making printouts necessary for visual reference.
3. Avoid any color correction or retouching of images that is not absolutely necessary. Do not superimpose text captions over your images and set your camera so the date/time stamp is off. It is difficult to edit these things out of the images without losing important details.
4. Include an image of the exterior of the building, as well as individual images of all stained glass windows. It is not necessary to submit individual images (or window data forms) for clear, non-leaded windows, although they should be identified on the building diagram.
5. Include the name of the photographer(s) to be credited when the images are published on-line. Donation of images to the Michigan Stained Glass Census constitutes release of those images and their copyright to the Michigan Traditional Arts Program/Michigan State University Museum for educational use (this does not apply to images of objects held in the collections of other museums).

Note: Point out significant details in certain windows by taking close-up views. Additional photographs or picture postcards of the windows and building may be obtained from the building where the windows are located, please ask your building contact person.

Equipment list: Camera, tape measure, pen, pencil, flashlight, binoculars and MSGC forms.



Supported in part by the
Michigan Council for Arts
and Cultural Affairs.

REV 05/2009

Use of Archival Materials: Information about the windows and building may be available through archival materials such as church or building histories, dedication programs, printed guides to the windows, correspondence and contracts with the artist or studio, receipts for payment, newspaper articles, picture postcards, etc. Ask whether these records are available in the building's archives. They may also be in the files of the *local library*, the *local historical museum or society*, or the *local newspaper*. Good sources of information may be obtained from persons associated with the building, such as a pastor, historian, secretary, administrator, or member.

Numbering Window Locations and Shapes (Forms A & B): Form A provides space for a sketch of the building floor plan, so that you can show the location of each window (or add an additional sheet if you need more room). Number each window on the floor plan, according to one of the numbering systems on Page 3. Use the same numbers to identify each window on Form B and on digital images and photographs.

Name of Artist or Studio (Form B): If written records indicate the name of the studio or artist that created the window, enter that information on Form B. If the name of the studio or artist appears on the window, enter it on Form B exactly as it appears on the window.

Type of Glass and Technique (Form B): See Page 4 of the Instructions.

Subject Matter (Forms A & B): Windows with images that represent human or animal figures, landscapes, and/or symbols are classified as **Pictorial Windows**. Windows with non-representational images, such as geometric designs, are **Non-Pictorial Windows**. To identify the subject matter of PICTORIAL WINDOWS, it may help to consult a reference book such as those listed at the bottom of Page 4.

Be sure to list any images that depict ethnic, denominational, local, state, or national events or leaders, or that express social or humanitarian concerns. Ask persons familiar with the windows whether there are any unusual images you may have overlooked. If possible, take close-up pictures of these special images.

Inscriptions: (Scriptural, memorial, etc.) Copy any inscriptions on the windows exactly as written, whether in script, upper or lower case, and with misspellings, if any.

Window Condition, Protection, and Restoration (Form B): List any problems such as deterioration of paint, cracking or buckling of window, etc. If restoration has been done, record the date and name of the restorer. If exterior protection has been installed, indicate the type of material used (*Glass, Lexan, etc.*) and when it was done.

When you have completed filling out one Form A for each building and a separate Form B for each window (unless the windows are identical), send in all forms, digital images (on CDs), print-outs of images, sketches, and copies of any other material that you think should be included. (This might include church histories, guides to windows, dedication programs, correspondence, newspaper articles, etc.) *Keep one copy of your census information in a secure place away from your building (i.e., safe deposit box).*

Send to: **Michigan Stained Glass Census**
Michigan State University Museum
East Lansing, MI 48824-1045

Phone: 517-432-3800 or 517-627-8973
E-mail: stainedglass@museum.msu.edu
Web: <http://museum.msu.edu/museum/msgc/index.html>

***Thank you for helping to discover, document and preserve
Michigan's stained glass heritage!***

Numbering Windows and Window Shapes for the Census Forms

Two systems for numbering windows are described below. Both the *Symmetrical System* and the *Consecutive System* require that numbering begin at the focal point of the space to be surveyed. The focal point might be an altar, ark, podium, judge's bench, etc. **Number all windows** whether or not they contain stained glass. Ground floor windows should be numbered from 0 to 99; windows on the next level should be numbered from 100 to 199 and so on. Choose one numbering system for the windows you are recording and use those numbers for filling out **Form B**. Use the same numbers to keep track of your images.

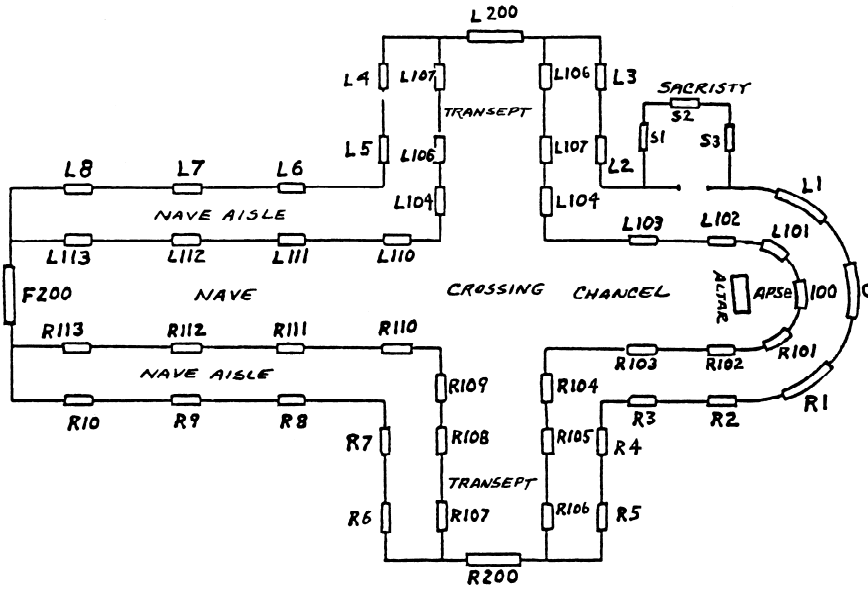

Symmetrical System

In this full cathedral plan, the center of the apse behind the high altar is the focal point. Windows within the same level are numbered left "L" and right "R" consecutively. Notice that the sacristy, a separate room, is numbered separately, preceded by "S" for sacristy and from left to right clockwise.

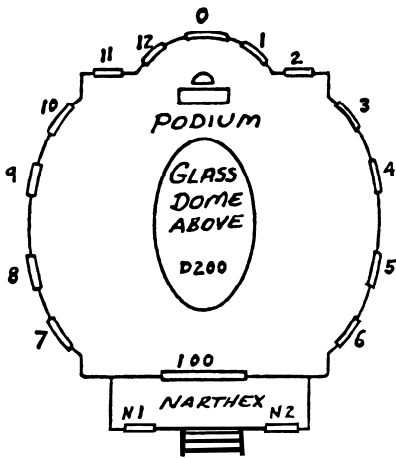

Consecutive System

Example of a building with two levels of windows and a glass dome in the ceiling. The building is numbered consecutively and clockwise from the focal point behind the podium. The narthex is numbered separately and the dome on the third level is numbered "D200."

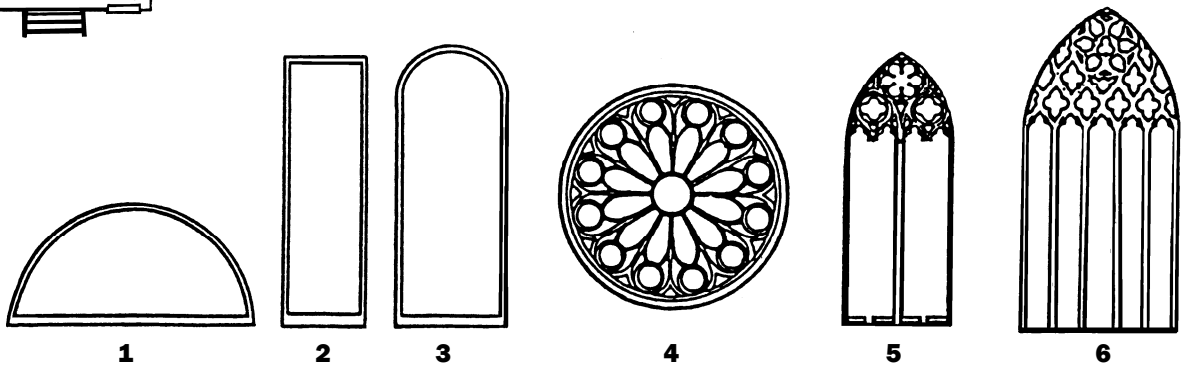

Window Shapes: Six general window shapes are shown. Select the shape that is most like the window you are recording and enter that number on **Form B** in the space after "Window Shape".

Types of Glass and Techniques

Antique: Transparent glass, hand-blown with irregularities of "medieval" glass. Refers to the technique, not the age. Variations include streaky, flashed, seedy, crackle.

Cathedral: Transparent, machine-rolled stained glass. Can have different surface patterns which may make the glass translucent.

Copper Foil: (1) Mil-thickness copper foil backed with adhesive; (2) The technique of joining pieces of glass where the foil is centered on edge of each glass piece, wrapped around to cover small portion of back and front faces of glass. Pieces are abutted, solder melted over exposed foil surfaces so that pieces become joined. Often used with small pieces, lamps.

Drapery: Opalescent type of glass formed into ridges to resemble drapery folds.

Enamels: Colored ground glass which, when applied with a brush, fuses to the base glass when fired in kiln; transparent or opaque; not used for tracing; generally of a color, such as blue, green, carmine, magenta; not as weather resistant as vitreous paints.

Etching: Processes that alter the surface of the glass, as in acid etching or abrasive etching (with sand or modern abrasives such as aluminum oxide, silicon carbide). Often a layer of another color or clear glass is revealed, as in "flashed glass."

Jewels: Glass nuggets inserted into windows for a decorative effect.

Lead Came: Most common form of connecting individual pieces of glass. Usually of an "H" profile, the heart (or central bar) rests between the segments of glass, and the flanges (side bars) are pressed down to hold the glass in place.

Opalescent: Semi-opaque machine-rolled glass, often with two or more colors streaked together; often has a milky appearance; made popular by Tiffany and La Farge.

Plating: The use of one or more pieces of glass on top of another of a different texture or color and leading them together for a special effect. Often used during the Opalescent era.

Silver Stain: A nitrate applied to the exterior of glass, popular since the 14th century. When fired, it produces a variety of yellow shades.

Slab (Dalle de Verre): Thick slab of cast stained glass that is cut or broken and held together by a matrix of poured epoxy. Concrete matrix is no longer used.

Vitreous Paint: Usually black, brown and flesh red; used primarily for tracing and matting; fired for weather resistance; very opaque.

The following books will be helpful in identifying the religious subject matter that you may find in windows. They should be available in your local bookstores and libraries:

George Ferguson. *Signs and Symbols in Christian Art*. New York: Oxford University Press, 1954.

James Hall. *Dictionary of Subjects and Symbols in Art*. New York: Harper & Row, 1974.

Nola Tutag. *Discovering Stained Glass in Detroit*. Detroit : Wayne State University Press, 1988.

The following titles are available from the Stained Glass Association of America, (800) 888-7422:

Jean Farnsworth, *Census of Stained Glass Windows in America: A Surveyor's Guide*

The Census of Stained Glass Window in America Inc., *Conservation and Restoration of Stained Glass: An Owner's Guide*

Stained Glass Association of America: Repair and Restoration of Historic Stained Glass Windows



Michigan
Stained Glass
Census

Form A: Building Data

(Please type or print in black ink.)

For office use only: MSGC# _____

Date: _____

Name of Building: _____

Function or type of Building: _____

Denomination (if applicable): _____

Address of Building: _____
street city state zip code

County: _____

Contact Person, Title: _____ Phone: _____

E-mail: _____ Web address: _____

Date of Construction: _____ Architect, city: _____

Dates of Alterations: _____ Architect, city: _____

No. of pictorial windows: _____ No. of non-pictorial windows: _____
(including figural, scenic, symbolic, historic, humanitarian, etc.)

Archival sources for building information: _____

Number of images sent: slides _____ photos _____ CDs _____ # of images on CDs _____
(Remember to include slide or photo of building exterior)

Sketch of Building Floor Plan _____
(Locate and number each window on plan. See Page 3 of instructions)

Census Taker: _____ Photographer (if different): _____

Organization (if applicable): _____

Address of Census Taker: _____
street city state zip code

Telephone: _____ or _____ Fax: _____

E-mail: _____



Form B: Window Data

(Please type or print in black ink.)

For office use only: MSGC# _____

Date: _____

Name of Building: _____

City: _____

Census Taker: _____

*Michigan
Stained Glass
Census*

Window location and no, on plan: _____ Window shape: _____ Date of window: _____
(see Page 3 of instructions for help with above)

Name of artist or studio that created window: _____

City, state: _____

Is the name of the artist on the window? _____ If so, how does it appear? _____

Dimensions of window: Height: _____ Width: _____

Type of Glass and Technique: (see Page 4 of instructions. Check as many as apply. Leave blank where unsure)

- Opalescent Glass Lead Came Vitreous Paint Etching or Sandblasting
- Antique or Cathedral Glass Copper Foil Silver Paint Drapery Glass
- Enamel Paint Plating Jewels or Cast Glass Slab or Facted Glass (Dalle de Verre)

Subject of window: _____
(If window is non-pictorial, indicate that on above line)

Brief description of subject: _____

List any images that depict ethnic, denominational, local, state, or national leaders or events: _____

List any images that depict social or humanitarian concerns: _____

Inscriptions: (Scriptural, memorial, etc.) _____

Is there a coat of arms? _____ If so what does it represent? _____

Donor of window: _____ Memorial to: _____

Condition of window: (List any problems here)

Restored by: _____ City, state: _____ Date: _____

Exterior protection? _____ Type of material: (Glass, Lexan, etc.) _____ Date installed: _____

Archival Sources for window information: _____